

TRUCK / DIESEL: Intelligent Parking Lot Controller (IPLC) M210 Operation

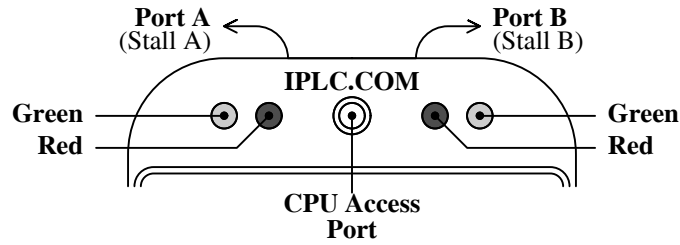

IPLC M210 Diagnostic Lights

Each stall or port has two associated lights, one green the other red. These lights reflect the status of the IPLC and the condition of any attached loads, such as block heaters, battery blankets, interior heaters, etc. The various light combinations and status is shown in the table below.

Stall Lights		Load Attached	Load Status Description
Green	Red		
Flashing Slowly	OFF	NO	Power is available. Ready to accept user load.
Flashing Slowly	OFF	YES	User equipment has an open circuit condition.
ON	OFF	YES	All is OK! Load is accepted.
Flashing Quickly	OFF	YES	Load is too small. Loads MUST BE at least 1/4 Amp.
OFF	ON	YES	Load is OVER maximum load limit. Unplug - reduce load - retry.
OFF	Flashing Quickly	YES	Load is greater than 15 Amps! Possible short circuit!
OFF	OFF	N/A	Power is NOT available. Call service personnel.

IPLC M210 Diagnostic Lights & Load Status Table

Package Contents:

One IPLC M210 dual circuit controller, pre-wired industrial outlet, specification grade thermal-plastic cover, seals, mounting hardware/instructions, and commissioning procedures. The IPLC comes pre-programmed with a Diesel standard schedule averaging 50% in savings (see program profile below) with a load limit of 15 Amps and a two hour initial power delay.

Trucking / Diesel: Factory Pre-Programmed Schedule

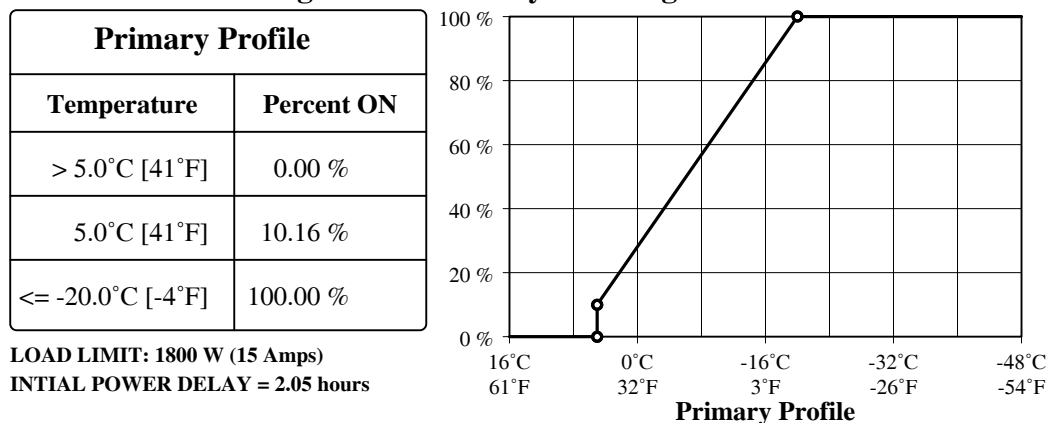

Intelligent Parking Lot Controller (IPLC) M210 Wiring and Commissioning Procedure

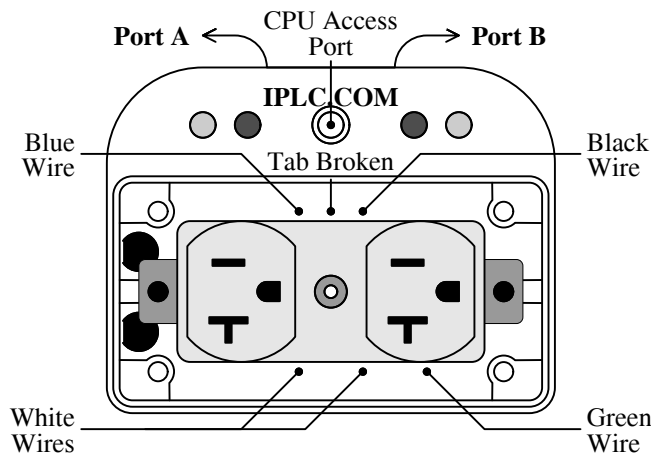

IPLC M210T Wiring Diagram (Frontview)

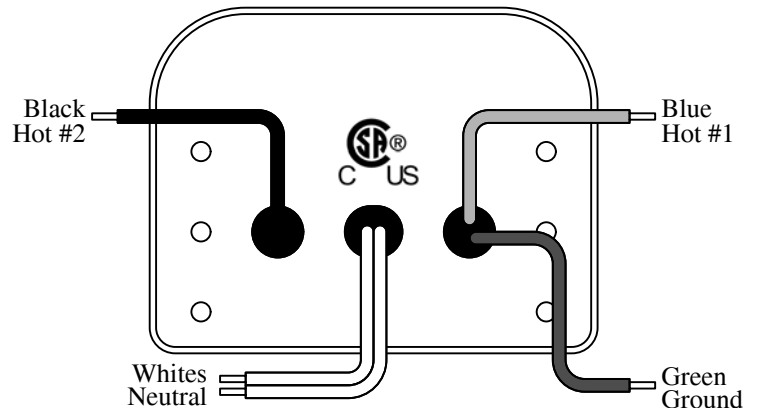

IPLC M210 Wiring Diagram (Backview)

Electrical & Wiring Specifications: Dual 125 VAC, AC supply, 15 Amps rms, 60 Hz circuit operation, resistive loads only. 240 VAC single phase split circuit with neutral, 208 VAC Line-to-Line 3 phase with neutral. *please refer to IPLC M210 wiring diagram BACKVIEW (shown above) and table (shown below).

Configuration	Wiring	Notes
Dual Stall / Dual Circuit	Blue - Hot #1 Black - Hot #2	
Dual Stall / Single Circuit	Blue - Hot #1 Black - Hot #1	Connect Blue and Black with available Hot. Set load limit to 900 Watts using IPLC Data-Mate.
Single Stall *	Option #1 Blue - Hot #1 Black - Hot #1	Connect Blue and Black with available Hot. Configure for Single Stall operation using IPLC Data-Mate (recommended method).
	Option #2 Blue - Hot #1 Black - Neutral	IPLC Data-Mate NOT available: Connect Blue with available Hot. Connect Black with Neutral.
COMMON WIRING: Whites - Neutral Green - Ground		
* - For Single Stall operation: ONLY Port "A" (see frontview above) will be available for use. Option #1: Port "B" will always have a red light. Option #2: Port "B" will always have no lights. It is recommended that the Port "B" receptacle be capped off with a glued child protector.		

NOTE: Take special care to ensure the marrettes make tight wire connections! If available wiring is corroded, it is recommended to trim wire and then connect. The IPLC M210 is a flush mount style which does not require any access to the back of the unit. This makes the M210 suitable for almost ALL parking post or concrete embedded electrical box installations. The CPU access port is now on the front of the unit (see FRONTVIEW above), this access port enables an IPLC Data-Mate to reprogram and collect performance data for the IPLC.

Commissioning Procedure: Connect the IPLC as described above, reset breakers, the units should flash "Green" after ~4 seconds, assert a test load which does not violate the preprogrammed load limits (a standard interior heating load with selectable wattage is suitable). The outlets "Green" light will be lit solid and power will be delivered to this load if all is well. A solid "Red" light will indicate the applied load is too large. Remember to assert the load for each outlet and only a short connection period is required to verify proper operation. If the "Green" lights do not flash after ~10 seconds (and you are sure power is applied to both circuits) this indicates a poor wiring connection. Turn off power, reaffirm the wiring connections and repeat.

IPLC Warranty: The IPLC has a 3 year warranty on materials and workmanship, this covers normal use of the product only and does not cover abuse, accidental damage or vandalism. However, \$50.00 Cdn. funds factory credit (based on IPLC retail price of \$140.00) is provided for any returned IPLC unit towards the purchase of a replacement unit, regardless of purchase date, condition or circumstances of the returned unit. All software updates are free for the life of the product. Software updates require an IPLC Data-Mate and will be made available on IPLCs' web site www.iplc.com as they become available.