

IPLC M210 Diagnostic Lights

Each stall or port has two associated lights, one green the other red. These lights reflect the status of the IPLC and the condition of any attached resistive loads, such as block heaters, battery blankets, interior heaters, etc. The various light combinations and status is shown in the table below.

Stall Lights		Load Attached	Load Status Description
Green	Red		
Flashing Slowly	OFF	NO	Power is available. Ready to accept user load.
Flashing Slowly	OFF	YES	User equipment has an open circuit condition.
ON	OFF	YES	All is OK! Load is accepted.
Flashing Quickly	OFF	YES	Load is too small. Loads MUST BE at least 1/4 Amp.
OFF	ON	YES	Load is OVER maximum load limit. Unplug - reduce load - retry.
OFF	Flashing Quickly	YES	Load is greater than 15 Amps! Possible short circuit!
OFF	OFF	N/A	Power is NOT available. Call service personnel.

IPLC M210 Diagnostic Lights & Load Status Table

Package Contents & Unit Operation

This package contains one IPLC M210 dual circuit controller with 20 amp rated WR pre-wired industrial outlet, gasket, mounting hardware, and instructions/commissioning procedures. The IPLC comes pre-programmed with a standard schedule and a factory set load limit of 15 amps. When a load is attached there is a 2 1/4 minute test time, power is provided at any temperature allowing for testing of units. This is followed by a two hour initial power delay, no power is provided at any temperature. Following this delay the unit will start to cycle, checking the outside temperature every 4 1/2 minutes. It will provide power for a percentage of time based on the outside temperature as outlined in the program profile below. A cover is required and is not included. The M210TN unit is the one recommended for installations requiring GFCI protection however it is NOT included in the M210 unit. There are two options for adding GFCI protection, 1) two single pole GFCI breakers per unit at the panel; 2) two GFCI blank face receptacles per unit between the breakers and the M210 unit. If using GFCI protection devices, the IPLC “Power In” **MUST BE** wired to the GFCI device’s **LOAD** terminals. Visit www.iplc.com/downloads and reference the “M210 GFCI Wiring Options” document for complete details. Due to how the M210 control functions you can not replace the receptacle in this unit with a GFCI receptacle.

Factory Pre-Programmed Schedule

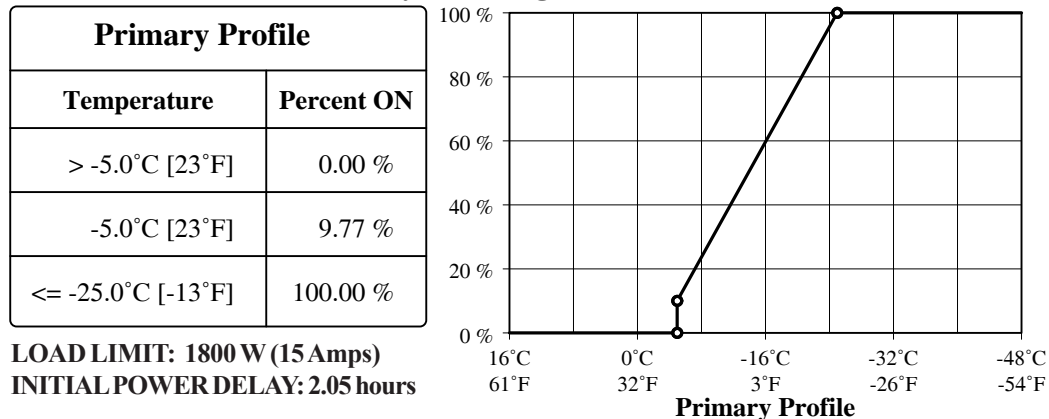

Intelligent Parking Lot Controller (IPLC) M210TN Wiring and Commissioning Procedure

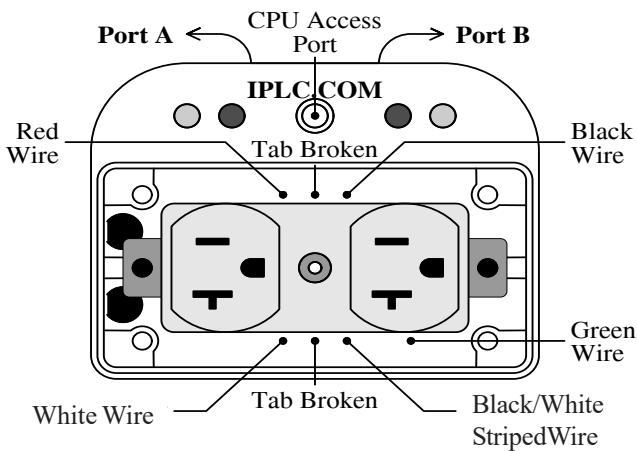

IPLC M210TN Wiring Diagram (Front View)

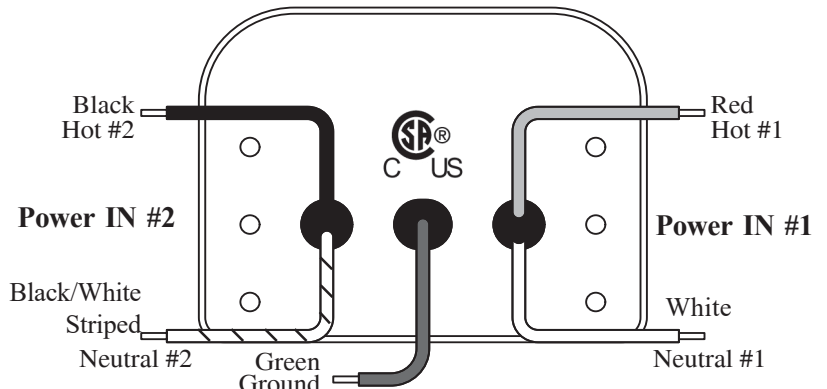

IPLC M210TN Wiring Diagram (Back View)

Installation, Electrical and Wiring Specifications

The IPLC M210 is a flush mount style and there is no access into the back of the unit. The CPU access port on the front of the unit (see FRONTVIEW above), enables the Data-Mate (available separately) to reprogram and collect performance data for the IPLC. A cover is required and NOT included, one must be added in accordance with national and local electrical codes.

Electrical Specifications

- Dual 125 VAC, AC supply
- 60 Hz circuit operation
- 240 VAC single phase split circuit with neutral
- 20 Amps rms
- Resistive loads only
- 208 VAC Line-to-Line 3 phase with neutral

Wiring details refer to IPLC M210 wiring diagram BACKVIEW (above) and table (below).

Configuration	Wiring	Notes
Dual Stall/Dual Circuit	Red - Hot #1 Black - Hot #2	
Dual Stall/Single Circuit	Red & Black Together - Hot #1	Connect Red & Black together with available Hot. Set load limit to 900 Watts using IPLC Data-Mate.
Single Stall Option 1	Red & Black Together - Hot #1	Connect Red & Black together with available Hot. Configure for Single Stall operation using the Data-Mate. Port B will always have a red light (recommended method).
Single Stall Option 2	Red - Hot #1 Black & Neutrals - Neutral	Data-Mate is NOT available, connect Red with available Hot. Connect Black with Neutral. Port B will always have no lights.

This model has a split Neutral (Neutral #1 is White, Neutral #2 is Black/White striped). Be sure each Neutral is connected to its associated Hot Neutral terminal (Neutral # 1 & #2 shown above). If only one Neutral is provided, wire Neutral #1 and #2 with this available Neutral.

Common Wiring: White & Black/White Striped - Neutral Green - Ground



Use CAUTION When Installing This Product

To prevent severe shock or electrocution always turn the power OFF at the service panel before working with wiring. Installation and service to be performed by a qualified installer. If available wiring is corroded, it is recommended to trim wire and then connect. **The Line Hots Must Be Connected To The Device Hots (Hot #1 & #2 shown above).**

Commissioning Procedure is as follows: Connect the IPLC as described above, be sure the marrettes make tight wire connections. Reset the breakers, the units should flash "Green" after ~4 seconds. Use an **OUTLET CIRCUIT TESTER** to test each half of the outlet to ensure the power is wired properly to the device. The Outlet Circuit Tester should verify that the hot, neutral and ground are properly connected. To complete the commissioning procedure, assert a test load which does not violate the preprogrammed load limits (a standard interior heating load with selectable wattage is suitable). The units "Green" light will be lit solid and power will be delivered to this load if all is well. A solid "Red" light will indicate the applied load is too large. Remember to assert the load for each side of the outlet to verify proper operation. If the "Green" lights do not flash after ~10 seconds (and you are sure power is applied to both circuits) this indicates a poor wiring connection. Turn off power, reaffirm the wiring connections and repeat. GFCI testing procedure is available at www.iplc.com/downloads.